

VENTILATORI ASSIALI

■ VENTILATEURS AXIAUX ■ AXIAL FANS ■ AXIALVENTILATOREN ■ VENTILADORES AXIALES

ESECUZIONE

• Configuration • Arrangement
• Ausführung • Ejecución

4

MODELLO

• Modèle • Model
• Modell • Modelo

EA

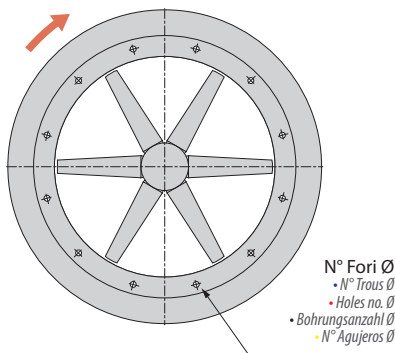
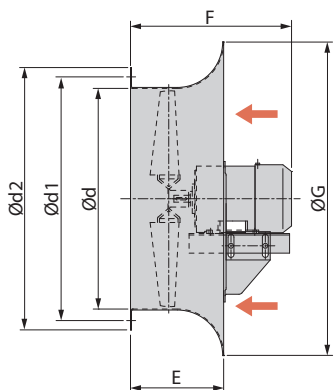

DIMENSIONI D'INGOMBRO E PESI SERIE "EA"

■ DIMENSIONS D'ENCOMBREMENT ET POIDS SERIE "EA"

■ OVERALL DIMENSIONS AND WEIGHT SERIES "EA"

■ AUSMAßE UND GEWICHTE SERIE "EA"

■ DIMENSIONES QUE OCUPA Y PESOS SERIE "EA"

Tipo • Type • Type • Typ Tipo		Peso • Poids • Weight • Gewicht • Peso kg	Ventilatore Esecuzione 4 • Ventilateur Configuration 4 • Fan Arrangement 4 • Ventilator-Ausführung 4 • Ventilador Ejecución 4							
Ventilatore • Ventilateur • Fan • Ventilator • Ventilador	Motore • Moteur • Motor • Motor • Motor		d	d1	d2	G	E	F*	N°	Ø
EA 310/2 EA 310/4	71B2 63A4	14 12	315	366	400	465	160	320 285	8	12
EA 350/2 EA 350/4	80B2 63A4	18 12	355	405	440	512	170	335 285	8	12
EA 400/2 EA 400/4	80B2 63A4	19 15	400	448	485	565	180	335 285	12	12
EA 450/2 EA 450/4	90L2 71A4	28 19	450	497	535	640	190	355 330	12	12
EA 500/2 EA 500/4 EA 500/6	100L2 71B4 71A6	39 23 23	500	551	585	707	200	432 330 330	12	14
EA 560/4 EA 560/6	90S4 71B6	35 28	560	629	665	785	215	385 314	12	14
EA 630/4 EA 630/6	100LA4 80B6	45 34	630	698	735	870	215	405 355	12	14
EA 710/4 EA 710/6	100LB4 90L6	55 48	710	775	815	965	225	445 390	16	14
EA 800/4 EA 800/6 EA 800/8	112M4 100L6 90L8	72 65 60	800	861	905	1075	250	495 465 390	16	14
EA 900/4 EA 900/6 EA 900/8	132M4 112M6 100L8	110 85 75	900	958	1005	1210	280	545 505 465	16	14
EA 1000/4 EA 1000/6 EA 1000/8	160M4 132S6 112M8	144 110 92	1000	1067	1107	1345	280	530 490 450	24	14
EA 1120/4 EA 1120/6 EA 1120/8	180L4 160L6 132SB8	286 200 154	1120	1200	1250	1490	315	765 685 580	24	14
EA 1250/6 EA 1250/8	180L6 160M8	294 221	1250	1337	1380	1670	355	780 700	24	14

Peso ventilatore in kg (completo di motore)

*) I dati di questa colonna possono variare in funzione della marca del motore montato sul ventilatore.

■ Poids du ventilateur en kilos (équipé de moteur)

*) Les données de cette colonne peuvent varier en fonction de la marque du moteur monté sur le ventilateur.

■ Ventilatorgewicht in kg (einschließlich Motor)

*) Die Werte dieser Spalte können je nach am Ventilator verbauter Motorenmarke geringfügig abweichen.

■ Fan weight in kg (complete with motor)

*) The data in this column may change in accordance with the make of motor installed on the fan.

■ Peso ventilador en kg (con motor)

*) Los datos de esta columna pueden variar en función de la marca del motor montado en el ventilador.

ESECUZIONE

- Configuration • Arrangement
- Ausführung • Ejecución

5

MODELLO

- Modèle • Model
- Modell • Modelo

EA

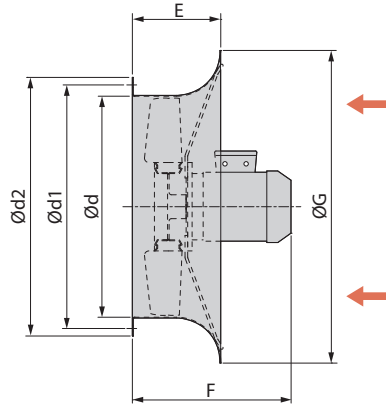

DIMENSIONI D'INGOMBRO E PESI SERIE "EA"

■ DIMENSIONS D'ENCOMBREMENT ET POIDS SERIE "EA"

■ AUSMAßE UND GEWICHTE SERIE "EA"

■ OVERALL DIMENSIONS AND WEIGHT SERIES "EA"

■ DIMENSIONES QUE OCUPA Y PESOS SERIE "EA"

Tipo • Type • Type • Typ • Tipo		Peso • Poids • Weight • Gewicht • Peso kg	Ventilatore Esecuzione 5 • Ventilateur Configuration 5 • Fan Arrangement 5 • Ventilator-Ausführung 5 • Ventilador Ejecución 5							
Ventilatore • Ventilateur • Fan • Ventilator • Ventilador	Motore • Moteur • Motor • Motor • Motor		d	d1	d2	G	E	F*	N°	Ø
EA 310/2 EA 310/4	71B2 63A4	14 12	315	366	400	465	160	320 285	8	12
EA 350/2 EA 350/4	80B2 63A4	18 12	355	405	440	512	170	335 285	8	12
EA 400/2 EA 400/4	80B2 63A4	19 15	400	448	485	565	180	335 285	12	12
EA 450/2 EA 450/4	90L2 71A4	28 19	450	497	535	640	190	355 330	12	12
EA 500/4 EA 500/6	71B4 71A6	23 23	500	551	585	707	200	330 330	12	14
EA 560/4 EA 560/6	90S4 71B6	35 28	560	629	665	785	215	385 314	12	14
EA 630/4 EA 630/6	100LA4 80B6	45 34	630	698	735	870	215	405 355	12	14
EA 710/4 EA 710/6	100LB4 90L6	55 48	710	775	815	965	225	445 390	16	14
EA 800/4 EA 800/6 EA 800/8	112M4 100L6 90L8	72 65 60	800	861	905	1075	250	495 465 390	16	14

Peso ventilatore in kg (completo di motore)

* I dati di questa colonna possono variare in funzione della marca del motore montato sul ventilatore.

■ Poids du ventilateur en kilos (équipé de moteur)
*) Les données de cette colonne peuvent varier en fonction de la marque du moteur monté sur le ventilateur.

■ Ventilatorgewicht in kg (einschließlich Motor)
*) Die Werte dieser Spalte können je nach am Ventilator verbauter Motorenmarke geringfügig abweichen.

■ Fan weight in kg (complete with motor)
*) The data in this column may change in accordance with the make of motor installed on the fan.

■ Peso ventilador en kg (con motor)
*) Los datos de esta columna pueden variar en función de la marca del motor montado en el ventilador.

VENTILATORI ASSIALI

■ VENTILATEURS AXIAUX ■ AXIAL FANS ■ AXIALVENTILATOREN ■ VENTILADORES AXIALES

CARATTERISTICHE IN MANDATA VENTILATORI SERIE "EF/D" e "EA" testate con flusso A (vedi pag. 5.3)

■ **CARACTÉRISTIQUES AU REFOULEMENT VENTILATEURS SÉRIE "EF/D" et "EA" essayés avec flux A (voir page 5.3)**

■ **OUTLET CHARACTERISTICS OF "EF/D" and "EA" SERIES FANS tested with flow A (see page 5.3)**

■ **EIGENSCHAFTEN DER AUSBLASSEITE FÜR VENTILATOREN DER REIHE "EF/D" und "EA" geprüft mit Strömung A (siehe Seite 5.3)**

■ **CARACTERÍSTICAS EN IMPULSIÓN DE LOS VENTILADORES SERIE "EF/D" y "EA" probadas con flujo A (ver pág. 5.3)**

Ventilatore • Ventilateur • Fan • Ventilator Ventilador	Motore • Moteur • Motor • Motor • Motor Motor	kW inst.	kW ass.	n	LWA [dB]	Tolleranza sulla portata +5%															
						• Tolérance sur le débit + 5% • Load tolerance +5% • Durchsatztoleranz +5% • Tolerancia respecto caudal +5%															
						Q [m³/s] P _s /P _t [Pa]															
Q		Q		Q		Q		Q		Q		Q		Q		Q					
P _s	P _t	P _s	P _t	P _s	P _t	P _s	P _t	P _s	P _t	P _s	P _t	P _s	P _t	P _s	P _t	P _s	P _t				
EF/D-EA310/2	71	0.55	0.4	2720	82	0,70	0,75	0,80	0,90	0,95	1,00	1,05	1,10	1,12							
						240	295	215	280	195	265	147	237	120	220	80	193	46	170	18	150
EF/D-EA350/2	80	1.1	0.8	2840	86	0,95	1,00	1,15	1,25	1,35	1,45	1,55	1,60	1,63							
						310	370	293	360	238	328	201	305	154	278	103	245	46	209	20	194
EF/D-EA400/2	80	1.1	0.9	2840	89	1,30	1,35	1,45	1,55	1,65	1,80	1,95	2,10	2,18							
						364	434	350	425	315	405	285	385	250	363	190	323	117	275	43	225
EF/D-EA450/2	90	2.2	1.9	2900	93	1,55	1,75	2,00	2,25	2,50	2,75	2,90	3,05	3,24							
						550	611	530	608	480	582	413	543	330	490	228	420	165	380	95	333
EF/D-EA500/2	100	3	2.7	2900	95	2,00	2,20	2,60	2,75	3,00	3,20	3,50	3,63	4,22							
						616	682	596	677	539	653	516	643	454	604	391	563	295	500	251	470
EF/D-EA560/2	132	7.5	7	2930	101	3,70	4,00	4,28	4,46	4,60	4,85	5,14	5,42	7,25							
						889	1030	832	1000	770	962	723	931	687	908	614	861	529	803	413	721
EF/D-EA310/4	63	0.12	0.05	1320	68	0,30	0,35	0,39	0,42	0,45	0,48	0,51	0,53	0,55							
						63	72	54	68	45	63	39	58	32	54	22	47	11	40	4	35
EF/D-EA350/4	63	0.12	0.08	1320	69	0,40	0,43	0,46	0,50	0,54	0,59	0,64	0,70	0,76							
						72	83	69	81	64	78	58	75	51	70	42	65	31	59	16	49
EF/D-EA400/4	63	0.12	0.09	1320	72	0,50	0,55	0,60	0,65	0,75	0,85	0,92	0,97	1,02							
						91	101	85	98	79	94	72	90	57	80	38	67	24	58	11	50
EF/D-EA450/4	71	0.25	0.2	1370	73	0,60	0,70	0,80	0,85	0,90	0,95	1,00	1,05	1,08							
						97	106	83	95	65	82	55	74	45	66	35	58	22	48	9	37
EF/D-EA500/4	71	0.37	0.32	1370	80	1,20	1,30	1,40	1,50	1,60	1,70	1,85	2,00	2,17							
						132	156	125	153	117	149	107	144	96	138	83	131	61	118	35	101
EF/D-EA560/4	90	1.1	0.8	1390	83	1,75	1,85	2,00	2,20	2,35	2,50	2,60	2,70	2,82							
						166	198	156	193	144	186	118	168	95	152	70	136	48	119	28	104
EF/D-EA630/4	100	2.2	1.7	1420	89	3,50	3,80	4,10	4,40	4,60	4,80	5,00	5,20	5,40							
						197	276	181	275	156	265	125	250	100	237	75	224	48	210	25	200
EF/D-EA710/4	100	3	2.7	1430	91	4,50	4,80	5,00	5,40	5,80	6,20	6,60	7,00	7,60							
						253	334	245	337	237	341	220	337	194	328	163	316	123	297	78	273
EF/D-EA800/4	112	4	3.6	1430	95	5,40	5,80	6,25	6,70	7,20	7,80	8,30	8,90	9,72							
						314	386	302	385	282	378	267	377	231	359	182	331	138	307	82	277
EF/D-EA900/4	132	7.5	7.13	1450	98	8,80	9,20	9,80	10,70	11,60	12,40	13,00	13,60	14,30							
						358	477	351	480	333	479	294	467	238	443	182	416	126	385	68	350
EF/D-EA1000/4	160	11	10.6	1460	100	11,60	12,10	12,70	13,30	13,60	13,90	14,20	14,40	18,7							
						356	491	351	496	340	500	320	497	310	494	300	490	280	480	267	475
EF/D-EA1120/4	180	22	19.5	1470	105	15,30	16,30	17,30	18,00	19,00	20,00	21,00	22,50	24,00							
						644	798	610	784	560	754	511	724	448	683	368	630	292	580	148	479
EF/D-EA500/6	71	0.18	0.1	880	76	0,7	0,78	0,87	0,95	1,03	1,11	1,19	1,28	1,36							
						53	61	50	61	46	59	41	56	35	53	27	48	20	44	11	39
EF/D-EA560/6	71	0.25	0.17	880	79	1	1,1	1,2	1,3	1,4	1,5	1,6	1,7	1,8							
						66	77	62	76	57	73	51	70	43	65	34	59	25	53	13	46
EF/D-EA630/6	80	0.55	0.48	930	80	2,48	2,66	2,81	2,94	3,06	3,17	3,28	3,39	3,53							
						78	118	69	118	59	108	49	108	39	98	29	98	20	88	10	88
EF/D-EA710/6	90	1.1	0.75	930	84	2,86	3,42	3,83	4,19	4,47	4,58	4,72	4,83	4,94							
						108	147	98	147	78	137	59	128	39	118	29	118	20	108	10	98
EF/D-EA800/6	100	1.5	1	930	85	4,03	4,67	5,03	5,39	5,72	6,03	6,14	6,28	6,42							
						128	177	108	167	88	157	69	137	49	128	29	118	20	108	10	108
EF/D-EA900/6	112	2.2	2	950	89	6,61	6,94	7,22	7,69	8,08	8,44	8,75	9,06	9,33							
						137	206	128	196	118	196	98	186	78	177	59	167	39	59	20	147
EF/D-EA1000/6	132	3	2.9	950	91	8,58	8,61	9,25	9,86	10,44	10,92	11,31	11,72	12,14							
						137	216	128	206	118	206	98	196	78	186	59	177	39	167	20	157
EF/D-EA1120/6	160	11	9	970	96	15,17	15,64	16,08	16,47	17,06	17,58	18,19	18,72	19,47							
						226	344	186	342	167	334	147	324	128	314	98	295	69	285	39	265
EF/D-EA1250/6	180	15	12.6	970	101	19,89	21,11	21,75	22,17	22,56	22,92	23,31	23,83	25,47							
						216	373	186	265	167	262	157	255	137	253	128	343	108	334	88	324
EF/D-EA 800/8	90	0.55	0.4	680	79	2,86	3,33	3,58	3,83	4,06	4,28	4,47	4,58	4,67							
						69	88	59	88	49	78	39	78	29	69	20	69	10	59	10	49
EF/D-EA900/8	100	1.1	0.8	700	82	4,44	4,97	5,36	5,67	5,94	6,17	6,39	6,58	6,78							
						78	118	69	108	59	108	49	98	39	88	29	88	20	78	10	78
EF/D-EA1000/8	112	1.5	1.17	700	84	6,00	6,50	7,00	7,50	7,90	8,20	8,40	8,70	8,95							
						79	115	72	114	59	108	48	104	38	100	27	93	19	90	10	85
EF/D-EA1120/8	132	3	2.75	700	90	8,00	8,60	9,20	10,00	10,50	11	11,50	12,00	12,90							
						153	194	145	192	133	187	115	178	99	169	83	159	65	149	40	131
EF/D-EA1250/8	160	5.5	5.1	710	92	14,50	14,86	15,42	15,78	16,22	16,58	16,89	17,53	18,67							
						118	206	108	196	98	196	88	196	78</							